

M5 THREADED INSERTS ON ALL VERSIONS USE M5 x 8mm LG. MACHINE SCREWS.

Ø .157in [4.00mm] FOR M5 x 8mm LG. SELF-TAPPING SCREWS

ASSEMBLY

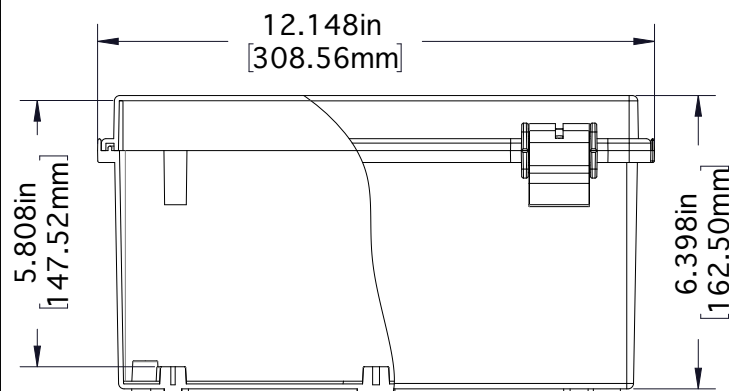

BODY

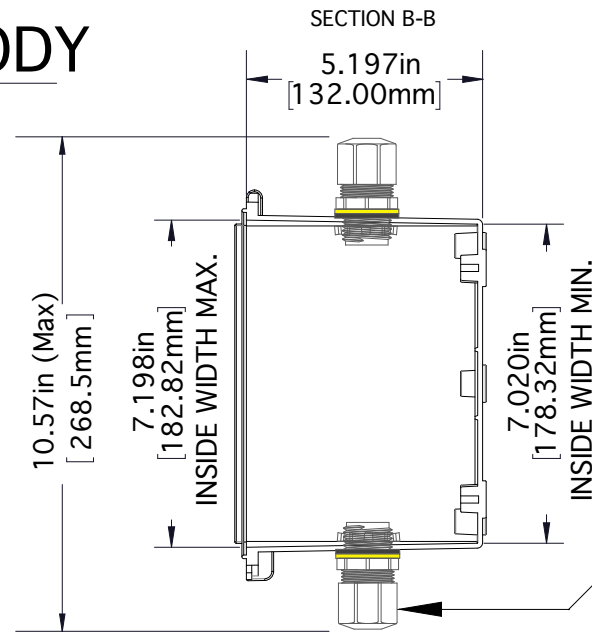

COVER

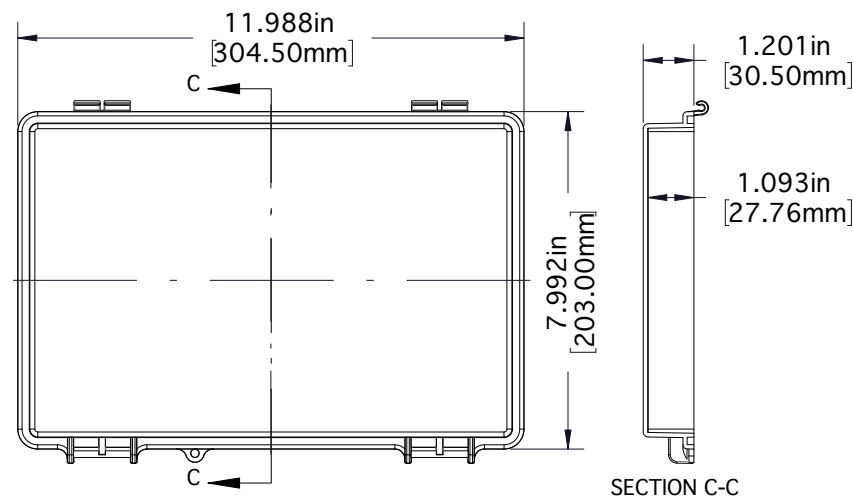

REVISION HISTORY			
REV	DESCRIPTION	DATE	APPROVED

ASSEMBLY ISOMETRIC VIEW

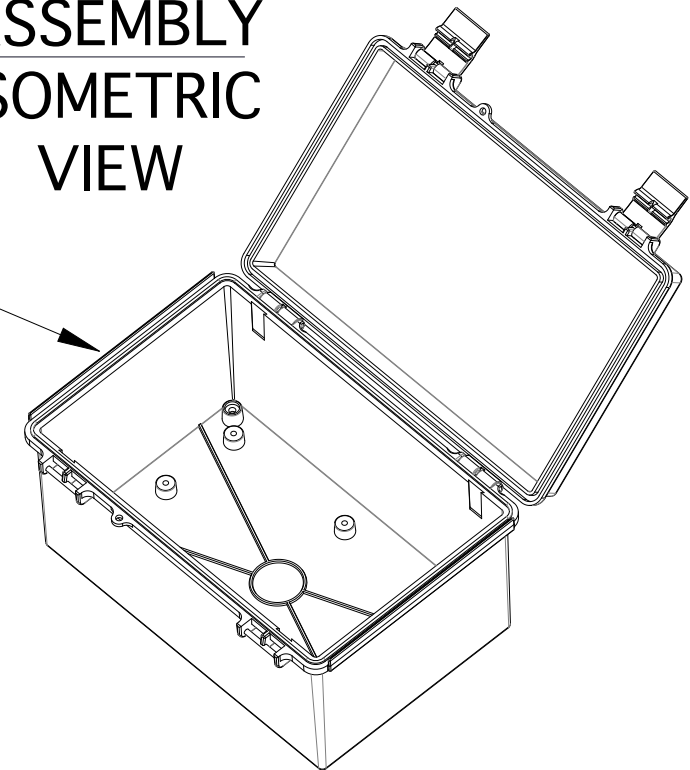

1/2" MNPT Sealing Cable Gland Detail

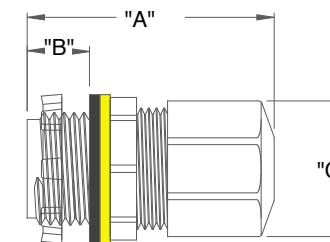

A = 1.792in (45.52mm)
 B = 0.502in (12.75mm)
 C = 0.978in (24.84mm)

Plastic Washer Shown in Yellow, EPR Sealing Gasket Shown in Gray 0.093in (2.36mm) Thick

Use with cables with diameter from 0.100 to 0.300in (2.54 to 7.62mm)

NOTES.

1. NEMA 4X, CSA/UL Listed Enclosure, PBT/PC plastic for Body, Polycarbonate plastic for clear door cover UL94-HB for Body & UL94-V0 for Door Flammability Rating, UV Stabilized with Polyurethane Internal Gaskets
2. 1/2" MNPT sealing cable glands along with mating tapped and threaded holes (not shown on drawing) with EPR sealing gasket 7 each on top and 7 each on bottom standard
3. Wall mounting kit supplied standard (not shown on drawing). 2" NPT Pipe Mounting Kit Optional (supplied & ordered separately).

TOLERANCES	
1 Place: ± .1	3 Places: ± .005
2 Places: ± .01	4 Places: ± .0005
Angular: ± 0.25°	

DRAWN BY TADP
CHECKED BY MJP
APPROVED BY MJP

		Advanced Sensor Technologies, Inc. Orange, California USA Toll-Free: 888-969-2784	
		TITLE 7MF NEMA 4X ENCLOSURE ASSEMBLY	
SIZE B	PROJECT 7MF	DRAWING NO. 7MF - Wall Mounting	REV /
SCALE Not to Scale	MODEL 7MF	SHEET 1	OF 1