



8X31 RADEL series pH sensor with "GR" 4 each protective tines installed into a 1" MNPT KYNAR twist lock receptacle



8X51 RYTON series pH sensor with "GR" 4 each protective tines configuration & Waterproofing Sealing Option "C" for Submersible Installation

® RADEL, KETASPIRE and RYTON are registered trademarks of Solvay

® Viton and Kalrez are registered trademarks of DuPont. Simriz is a registered trademark of Freudenberg Sealing Technologies (SIMRIT).

Twist Lock Quick Disconnect Bayonet Style pH & ORP Sensors for Inline Installations Requiring Easy & Fast Insertion & Removal from Process

ASTI offers unique solutions for process measurement problems

- Leading novel and proprietary solid-state industrial pH sensor & ORP sensor design and technology combined with built-to-order extensively configurable manufacturing offer the best possible service lifetime at the most cost effective pricepoint.
- Best reference service lifetime in process industry through proprietary, novel, non-porous, cross-linked, conductive polymer technology; Available in double junction (standard) or triple junction (optional "TJ") configurations
- Rugged industrial grade sensors can operate in a temperature range from -35 to 150 degrees Celsius at pressures up to 100 psig for quick-disconnect inline twist lock bayonet lock style installations
- The solid state reference is highly resistant to dehydration and our thick wall glass is nearly impervious to cracking, even under high pressure conditions to handle the most severe service applications.
- Base models for general purpose, high temperature resistant, ultra-high temperature resistant, slurry & viscous material resistant, acid/fluoride & HF resistant, pulp & paper resistant, aggressive dissolved gas & volatile organic solvent resistant, Oxidation Reduction Potential (ORP) and saturated sodium (brine) resistant.
- Selected optional features include Ammonia gas resistant ("A"), Chlorine gas resistant ("C"), Wide Range -0.5 to +14.5 pH Media Resistant ("V"), Organic Media Resistant ("L"), Solvent Resistant ("TS"), 3-Wire TC ("M"), ACCU-TEMP Fast Response Temperature Compensation (TC) Element ("X"), 2 each Protective Tines Only Configuration ("GRO"), 4 each Protective Tines ("GR") and Shielded Pre-amplifier Cable ("BL").
- Available with most any integral temperature compensation element (Pt100 or Pt1000 Standard), Solution Ground Liquid Earth (316SS or Platinum), Dual pH/ORP All-In-One Configuration and Conventional or Differential Analog preamplifier to allow for interfacing with most any existing OEM transmitter.
- Available end of cable terminations include tinned leads, BNC connector sensors without integral preamplifier.
- **Quick disconnect IP67 & NEMA 6P** rated waterproof and corrosion resistant **Q7M/Q7F snap connector** option is available for pH sensors and ORP sensors with integral preamplifiers.
- **Available in smart digital configurations for use with intelligent pH/ORP digital transmitters. Detailed information about this smart digital type configuration option can be found in the separate 3TX-HiQ digital pH/ORP measurement product webpage.**
- Quick-Disconnect Twist Lock Bayonet Style Receptacles allow for easy and fast insertion and removal from process line for calibration and cleaning. Available in KYNAR® (Poly-Vinylidene-Fluoride, PVDF) material of construction with stainless steel locking pins and KETASPIRE® (Poly-Ether-Ether-Ketone, PEEK) material of construction with Hastelloy C-276 locking pins.

- Double O-ring design ensures secure seal during operation; Standard material of construction is Viton®-75, with CV75, Simriz® 485 and Kalrez® 4079 Optional
- Back of sensor can be sealed with waterproofing option for use in immersion or submersible type applications as well as for inline use. For immersion and submersible installation it is recommended to add a protective tines option ("GR" or "GRO")
- Each standard sensor selection and/or special customized sensor design are based upon a thorough review of the customer supplied application information by senior in-house chemists to ensure that the best possible choice of available pH sensor or ORP sensor model and options is made at the lowest possible price configuration which is suitable for the intended process measurement & installation scheme.
- pH & ORP sensors manufactured with RADEL® (Poly-Phenyl-Sulfone, PPSU), KETASPIRE® (Poly-Ether-Ether-Ketone, PEEK) or RYTON® (Poly-Phenylene-Sulfone, PPS) for the sensor body housing material of construction.
- Thick-wall break resistant low-profile parabolic pH glass element for slurry and viscous type process media extends service life for tough installations. This type of rugged parabolic thick-wall, low-profile, break-resistant pH glass is now standard for all X3XX series pH sensors.
- Novel extreme dehydration resistant reference technology option allows sensor to endure prolonged exposure to dryness as well as intermittent wet and dry operation conditions for batch applications and uncertain fluid levels



Q7M sensor end of cable snap connector detail close-up view.



Q7F-Xm-TL Female snap to tinned leads extension cable



Q7M/Q7F connectors are NEMA 6P rated when properly interfaced (protective boots are supplied when not in use).

**APPLICATIONS FOR IOTRON™ IMMERSION SERIES
BUILT-TO-ORDER pH SENSORS & ORP SENSORS
WITH EXTENSIVE CUSTOMIZATION OPTIONS**

- Measurement in strong acids or bases
- Acid fluoride etching solutions
- HF waste treatment systems
- High Temperatures & Pressures
 - Examples include ammonium nitrate manufacturing, sugar extraction
 - Treatment of discharge from processes employing autoclaves
- Pulp digesters for Kraft type mills
- Bleaching lines for white paper mills
- Abrasives and Viscous Processes
- Extraction of precious metal ore with floatation tanks and concentrators
- Gold extraction circuits with cyanide (batch or continuous)
- Cyanide destruction with peroxide and/or sulfur dioxide
- Dissolved Sulfides such as hydrogen sulfide gas (H₂S), hydrogen sulfide (HS⁻) or sulfide ion (S²⁻)
- Solvent extraction (SX) with kerosene and other long chain hydrocarbons
- Measurement in most Volatile Organic Compounds (VOC) and most Organic Solvents
- Biodiesel and ethanol fuels
- Processes employing dissolved chlorine (Cl₂), chlorine dioxide (ClO₂), ammonia (NH₃), sulfur dioxide (SO₂) and nitric oxide (NO) and nitrous oxide (NO₂) sometimes together referred to as (NO_x) type gases
- Municipal or industrial wastewater treatment
- General Purpose pH monitoring or control for discharge compliance

**TECHNICAL CAPABILITIES OF IOTRON™ IMMERSION
SERIES BUILT-TO-ORDER pH & ORP SENSORS WITH
EXTENSIVE CUSTOMIZATION OPTIONS**

- Low pH range down to -0.5 (with ASTI calibration procedures and buffers)
- High pH range up to 14.5 (with ASTI calibration procedures and buffers)
- Low Temperatures down to -15 degrees Celsius (°C)
- High Temperatures up to 150 degrees Celsius (°C)
- High Pressures up to 150 psig (with RADEL or PEEK bodied type sensors)
- Insertion depths up to 6 feet into tank or line with compression fitting assembly installation scheme
- Mining Slurries up to 50% solid & particulate content
- Solids Content up to 12% consistency pulp
- Fluorides up to 50,000 ppm and -0.5 pH
- Support for measurement in most dissolved gases up to saturation
 - Examples include chlorine, chlorine dioxide, ammonia, sulfide gases
- Cyanides up to 10,000 ppm
- Almost All Organic Chemical Mixtures
 - Minimum ~1% aqueous content required to ensure stable readings
- Clean in Place (CIP) processes with hot acid and hot base for food and beverage and pharmaceutical use
- Sterilization with Peroxide (H₂O₂) and Ozone (O₃)
- Up to 600% Saturation Dissolved Oxygen (O₂)
- Fully submersible assembly that can be installed by thick reinforced vinyl tubing seal on cable
 - For best results the use of a suitable immersion tube, standpipe or guiderod is recommended to fix the installation location and to minimize mechanical related damage is recommended

Photos of Selected of Twist Lock Quick Disconnect Bayonet Style pH Sensors & ORP Sensors For Visualization of Available Materials of Construction, Configurations & Available Options



* 8X31 RADEL-KYNAR series pH sensor

* 8741 PEEK-KYNAR series pH sensor

* 8X52 RYTON-HDPE series sensor

* 8X51 RYTON-KYNAR series pH sensor

* 8X52 RYTON-HDPE series pH sensor

* "GR" 4 each protective tines

* Organic Solvent & Gas Resistant

* "PtD" Dual pH/ORP All-In-One Option

* "GR" 4 each protective tines

* "GR" 4 each protective tines

* 1"MNPT PEEK twist lock receptacle

* Optional Kalrez 4079 "O"-Rings

* "GR" 4 each protective tines

* Waterproofing "C" for fully Submersible Installations

* Wide Range MUGG pH glass

**Materials of Construction for Sensor Body of
Inline, Immersion & Submersion Series pH Sensors & ORP Sensors**

Body Housing RADEL®
Poly-Phenyl-Sulfone, PPSU
Grade R-5000 NT

Body Housing KETASPIRE®
Poly-Ether-Ether-Ketone, PEEK
Grade KT-880 NT

Body Housing RYTON®
Poly-Phenylene-Sulfone, PPS
Grade R-4-230-BL

8X31 Series Sensors

8X41 Series Sensors

8X52, 8X51 Series Sensors

® RADEL, KETASPIRE and RYTON are registered trademarks of Solvay

Dimensional Drawings for 1" MNPT Twist Lock Quick Disconnect Bayonet Style pH Sensors & ORP Sensors for Inline, Immersion & Submersion Installations

1" MNPT TWIST LOCK SENSOR DIMENSIONAL DRAWINGS



Twist Lock pH Sensor Dimensional Drawing 8-1 Hemispherical pH Glass Element

- 8052/8051/8031/8041
General Purpose & Wide Range Resistant
- 8151/8131/8141 & 8231/8241
High Temperature & Ultra-High Temperature Resistant
- 8452/8451/8431/8441
Acid, Fluoride & HF Resistant
- 8651/8631/8641
Hydrogen sulfide gas (H₂S), hydrogen sulfide (HS⁻) or sulfide ion (S²⁻) Resistant
- 8731/8741
Aggressive Dissolved Gas & Volatile Solvent Resistant
- 8952/8951/8931/8941
Saturated Sodium (Brine) Resistant

Twist Lock pH Sensor Dimensional Drawing 8-2 Parabolic Thick-Wall Break-Resistant pH Glass

- 8352/8351/8331/8341
Slurry & Viscous Media Resistant
- 8551/8531/8541
Pulp & Paper Resistant

Twist Lock ORP Sensor Dimensional Drawing 8-1-Pt Low-Profile Platinum Ball Style ORP Sensing Element

- 8852/8851/8831/8841
Oxidation Reduction Potential (ORP)



8X31 Twist Lock Sensor
Installed into 1" MNPT PEEK
Twist Lock Receptacle*

* 8X41 series PEEK bodied twist lock sensors MUST use a PEEK receptacle for inline use. All other twist lock sensors (8X52, 8X51 & 8X31) can either use the KYNAR receptacle (50 psig max) or PEEK receptacle (100 psig) as desired.



8X31 Twist Lock Sensor with "GR" 4 each Protective Tines Option*

* Immersion or Submersible installations for twist lock sensors require that either the "GR" or "GRO" option is invoked to avoid breakage during field use of maintenance operations such as cleaning and re-calibration.



1"MNPT KYNAR® PVDF and KETASPIRE® PEEK Twist Lock Receptacles for Quick Disconnect Inline Installation

PEEK receptacle up to 100 psig (left) & KYNAR receptacle up to 50 psig (right)

Please carefully check the recommend maximum temperature and pressure rating of your twist lock sensor prior to installation. Note that the max pressure rating for each twist lock sensor may be dependent upon whether it is used with the KYNAR® PVDF or KETASPIRE® PEEK twist lock receptacle.

1

2

3

REVISION HISTORY		
REV	DESCRIPTION	DATE

APPROVED

O-RINGS (2 EACH)

LOCKING PINS FOR TWIST-LOCK QUICK-DISCONNECT FEATURE

0.95" DIA.

1" - 11.5 NPT
1.31" DIA MAX

1.69"

1.25"

8.00"

0.3" MAX

A

A

NOTES

1. All dimensions are in inches, unless otherwise indicated with tolerances as detailed below
2. Sensor body material of construction is RADEL (8X31), PEEK (8X41) or RYTON (8X51, 8X52)
3. O-ring material of construction is Viton-75 standard; CV75, Simriz 485 & Kalrez 4079 Optional
4. Drawing as shown is without protective tines. The maximum displacement of the sensor past the end of the body in this configuration is 0.3" inches yielding a max overall length of 8.3 inches.
5. With Protective tines "GR" (4 places, 90 degrees apart) or "GRO" (2 places, 180 degrees apart) configurations overall sensor length is 8.00 inches.
6. This sensor is only suitable for inline installation when used with ASTI 1" MNPT Twist Lock Receptacle.
7. Do not use any sensor beyond the factory defined maximum temperature or pressure rating.

B

B



Advanced Sensor Technologies U.S.A.
Website: <http://www.astisensor.com>

TITLE
Sensor for Inline Twist Lock Quick Disconnect Use

SIZE	PROJECT	DRAWING NO.	REV
B	TWIST-LOCK	8-1 pH SENSORS	/

SCALE	Not to Scale	MODEL	8X31,8X41,8X51,8X52	SHEET	1	OF	1
-------	--------------	-------	---------------------	-------	---	----	---

2

1

3

1

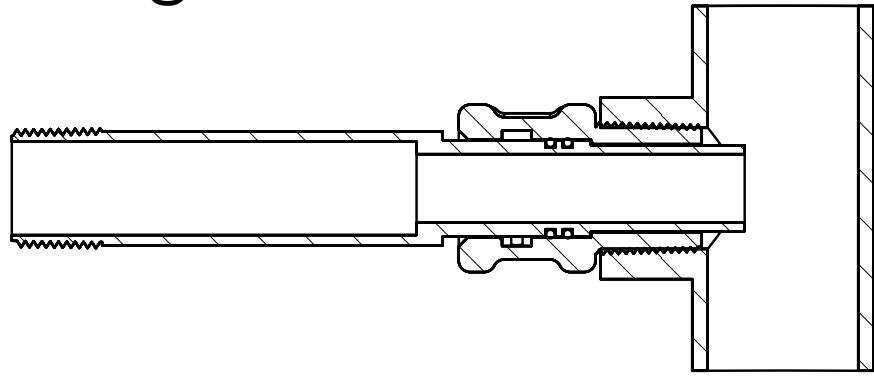

TWIST LOCK BAYONET QUICK DISCONNECT INLINE INSTALLATION ASSEMBLY

RECEPTACLE INTERFACED WITH 1" FNPT PIPE TEE

CROSS-SECTION TO LEFT

SIDE VIEW TO RIGHT

2

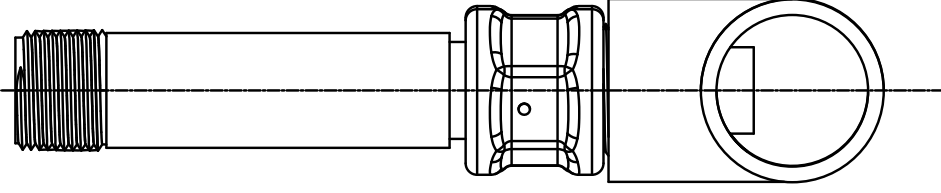

TWIST LOCK RECEPTACLE SELECTED FEATURES

LOCKING PINS

1" MNPT

3

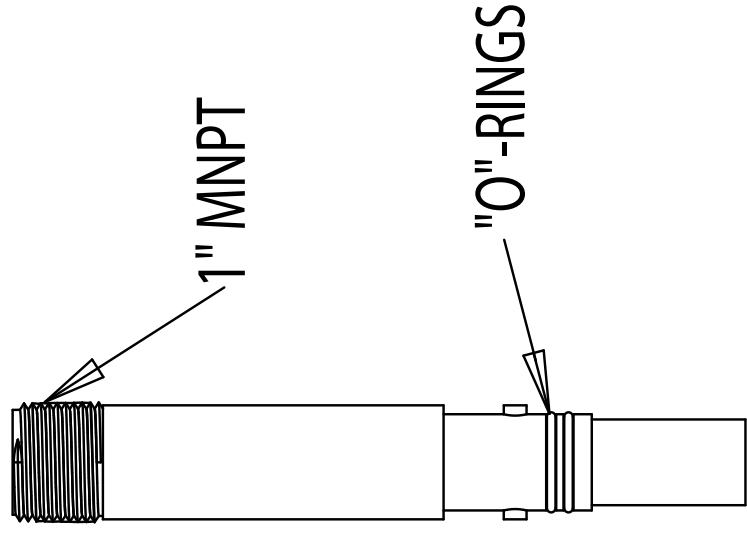

1" MNPT

"O"-RINGS

TWIST LOCK SENSOR SELECTED FEATURES

A

B

NOTES

1. Twist lock receptacles used with pH sensors must be installed such that the sensing tip will be angled at least 15 degrees below the horizontal up to max 90 degrees (tip straight down as shown above).
2. Receptacles for use with ORP sensors may be installed in any angle or position without restriction.
3. Receptacle Material of construction is either KYNAR (Item # 14003, 1"MNPT-TWISTLOCK-KYNAR-SS) for use up to 50 psig or PEEK (Item # 14024, 1"MNPT-TWISTLOCK-PEEK-HASTC) for use up to 100 psig
4. Twist Lock Sensor body material of construction is RADEL (8X31), PEEK (8X41) or RYTON (8X51, 8X52)
5. O-ring material of construction is Viton-75 standard; CV75, Simriz 485 & Kalrez 4079 Optional
6. The max insertion depth past 1"MNPT threads on twist lock receptacle is 0.8" to 1.0" inches for twist lock sensor in the default no tines configuration, depending upon exact model used.
7. Max insertion depth for twist lock sensors with optional protective tines is 0.7" inches for all models.
8. 1" MNPT Twist Lock receptacle should be used with ASTI Twist Lock Sensors for inline installations.
9. Do not use any sensor beyond the factory defined maximum temperature or pressure rating.

1

2

3



Advanced Sensor Technologies U.S.A.
Website: <http://www.astisensor.com>

TOLERANCES		DRAWN BY RH
1 Place: ± .1	3 Places: ± .005	CHECKED BY TADP
2 Places: ± .01	4 Places: ± .0005	APPROVED BY MJP
Angular: ± 0.25°		

TITLE 1" MNPT Twist Lock Quick Disconnect Assy		
SIZE B	PROJECT TWIST-LOCK	DRAWING NO. Twist Lock Inline Assy
SCALE Not to Scale		MODEL Twist Lock Assembly
SHEET 1		OF 1

1

2

3

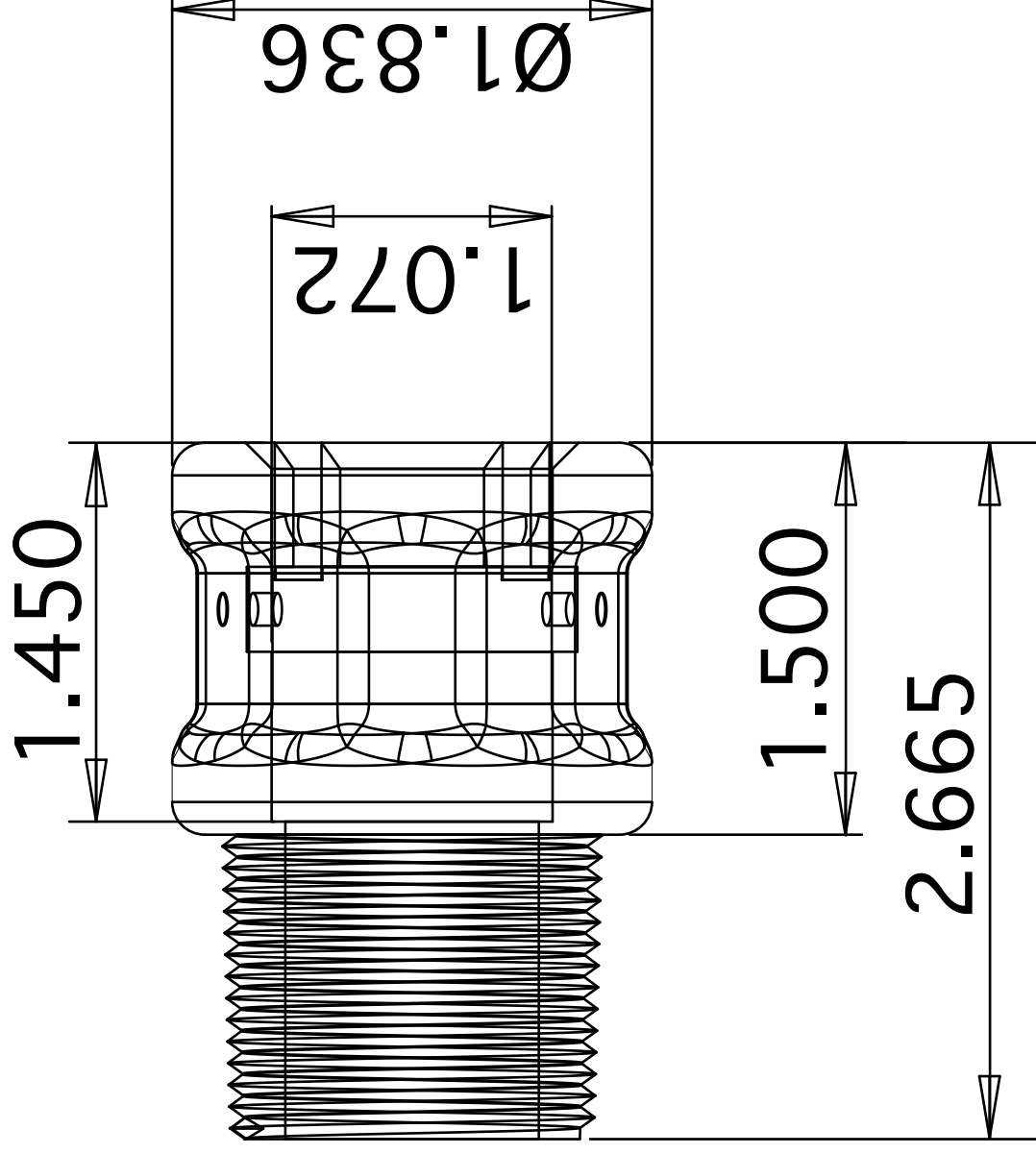

A

A

WRENCH FLATS
6 PLACES
1.500

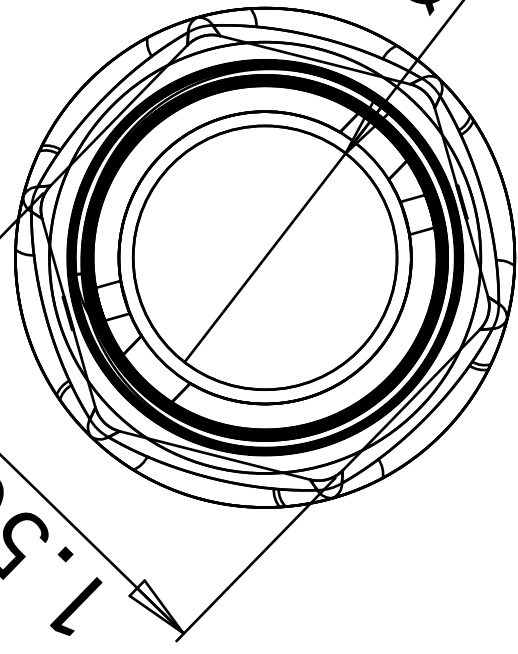

NOTES

1. All dimensions are in inches and intended for reference purposes only. No specific tolerance is guaranteed.
2. Receptacle material of construction is either KYNAR (Item # 14003, 1"MNPT-TWISTLOCK-KYNAR-SS) for use up to 50 psig or PEEK (Item # 14024, 1"MNPT-TWISTLOCK-PEEK-HASTC) for use up to 100 psig
3. Material of construction for locking pins to secure twist lock bayonet feature is Stainless Steel for KYNAR Receptacles & Hastelloy C-276 for PEEK Receptacles
4. 1" MNPT Twist Lock receptacle should be used with ASTI Twist Lock Sensors for inline installations.
5. Do not use any sensor beyond the factory defined maximum temperature or pressure rating.

B

B



Advanced Sensor Technologies U.S.A.
Website: <http://www.astisensor.com>

TITLE		1" MNPT Twist Lock Receptacle Dimensions	
SIZE	PROJECT	DRAWING NO.	REV
B	TWIST-LOCK	Twist Lock Receptacle	/
SCALE	Not to Scale	MODEL	1"MNPT-TWISTLOCK
		SHEET	1 OF 1

1

2

3



Twist Lock Quick Disconnect pH Sensor & ORP Sensor Selection Guide

Description of pH/ORP Sensor Series <i>KYNAR Junction for all 8XX1 Sensors HDPE Junction for all 8XX2 Sensor</i>	Sensor Body Housing RYTON® Poly-Phenylene- Sulfone, PPS <i>Large HDPE Junction</i>	Sensor Body Housing RYTON® Poly-Phenylene- Sulfone, PPS <i>Large KYNAR® Junction</i>	Sensor Body Housing RADEL® Poly-Phenyl- Sulfone, PPSU <i>Large KYNAR® Junction</i>	Sensor Body Housing KETASPIRE® Poly-Ether-Ether- Ketone, PEEK <i>Large KYNAR® Junction</i>
<i>General Purpose</i>	8052	8051	8031	8041
<i>High Temperature Resistant</i>	N/A	8151	8131	8141
<i>Ultra High Temperature Resistant</i>	N/A	N/A	8231	8241
<i>Slurry & Viscous Material Resistant</i>	8352	8351	8331	8341
<i>Acid, Fluoride & HF Resistant</i>	8452	8451	8431	8441
<i>Paper & Pulp Resistant</i>	N/A	8551	8531	8541
<i>Sulfide Resistant</i>	N/A	8651	8631	8641
<i>Aggressive Dissolved Gas & Volatile Organic Solvent Resistant</i>	N/A	N/A	8731	8741
<i>Oxidation Reduction Potential a.k.a. ORP</i>	8852	8851	8831	8841
<i>Saturated Sodium (Brine) Resistant</i>	8952	8951	8931	8941

® RADEL, KETASPIRE and RYTON are registered trademarks of Solvay



Twist Lock pH Sensor & ORP Sensor Options

- All 8X52/8X51/8X31/8X41 series pH sensors and ORP sensors are supplied standard (default) in the no tines configuration. The number of protective tines can be changed to the 2 each ("GRO") or the four (4) each protective tines ("GR") configuration. Using the 2 each protective tines type guard (or else no guard at all) is sometimes desirable for ease of cleaning, particularly in heavy slurry and high viscous media process media applications.
 - No guard configuration is most typically used for sensors with break resistant parabolic pH glass element (X3XX or X5XX series) or else for ORP sensors (X8XX series)
- Fast temperature compensation response may be desired for some installations with variable temperature conditions (Iotron™ ACCU-TEMP™).
 - The ACCU-TEMP™ ("X") option is recommended for most inline installations for best temperature compensation as well as for immersion and submersible installations where the sensor will be frequently removed from service for cleaning and recalibration.
- All twist lock sensors can have the waterproofing option added for fully submersible sensor installations.
- All series pH sensors or ORP sensors may be mounted from rear using the 1" MNPT threads for immersion installations using a suitable mating insertion tube, standpipe or guide rod.
- Sensors employed for immersion or submersible style installations should be in a with protective tines configuration (with guard) to minimize possibility of accidental breakage during handling for maintenance and continuous field measurement.
- The twist lock series pH sensors or ORP sensors can also be installed with a variable insertion depth into a process line or tank using a compression fitting only scheme.
- Sensors with integral preamplifiers can be supplied with the rugged field ready Q7M/Q7F NEMA 6P rated quick disconnect snap connector system.

* Additional charges may apply for these options. Not all options available on all models & not all combination of options are compatible (inquire to factory).

® Viton and Kalrez are registered trademarks of DuPont. Simriz is a registered trademark of Freudenberg Sealing Technologies (SIMRIT).

APPENDIX "A"

Custom Applications

Alpha Prefix

Dissolved Gas Resistant	"A" or "C"
Organic Media Applications*	"L"
Teflon Silicone Required*	"TS"
Triple Junction*	"TJ"
High-Level HF Resistant*	"HF"
Impact & break resistant low-profile parabolic pH glass for slurries*	"X3XX" & "X5XX" series
Aggressive Dissolved Gas & Organic Solvent Resistant Configuration*	"X7XX" series
Extreme Dehydration Resistant*	"E"

Custom Configurations

Alpha Prefix

ACCU-TEMP™ Option for Fast Temperature Response*	"X"
Low Impedance Glass*	"Z"
316SS Solution Ground Addition*	"Y"
Platinum Solution Ground Addition*	"Pt"
Platinum Solution Ground; 2 each half-cells for use on 2 channels/transmitter*	"PtD"
3-wire TC*	"M"
Upgrade from standard Viton® -75 to CV75, Simriz® 485 or Kalrez® 4079*	"W", "U" or "K" respectively
Add 4 each Tines (6X11 series only)*	"GR"
Add/Reduce to 2 each Protective Tines*	"GRO"
Reinforced Preamplifier Blue Cable*	"BL"



**Replacement pH & ORP Sensors
For Transmitters that support and/or require
Integrated Preamplifiers**

The instruments listed below require and/or support integral preamplifiers. Sensors to mate with these OEM pH & ORP transmitters are supplied with the appropriate integrated temperature compensation element, solution ground & OEM compatible high-impedance CMOS operational amplifier (a.k.a. preamplifier) as may be required to ensure full compatibility and optimal performance. Some manufacturers and analyzer models can support both sensors with or without preamplifiers on the same instrument. A sensor hook-up schematics for interfacing to the given OEM pH/ORP transmitter is supplied with each sensor, and some of the most common wiring schematic are posted on our website (please inquire for any not listed).

Fully Supported Hardware - FULL COMPATIBILITY

Manufacturer	pH & ORP Transmitters
Rosemount Analytical Liquid Division A Part of Emerson Process Management	LEGACY: 1050, 1181, 1055, 2081, 3081, 81, 54pH, 54epH, XMT MODERN: 1056, 1057, 56, 1066, 5081, 6081
Foxboro Analytical by Schneider Electric (a Division of Invensys)	LEGACY: 870IT MODERN: 875PH, 876PH, 873PH, 873DPX
Honeywell (formerly Leeds and Northrup, a.k.a. L&N)	LEGACY: 7030, 7075, 7076, 7079, 7081, 7082 , 7083, 7084, 7096, 9782 MODERN: UDA2182, APT2000PH, APT4000PH
Electro-Chemical Devices (a.k.a. ECD)	LEGACY: T20, T21, T27, T29, T30, C22 MODERN: T23, T28

* ASTI offers pH & ORP sensors compatible with the transmitters listed above as an alternative to mating OEM pH & ORP sensors detailed.

Trademarks (indicated with ™) are registered to the respective corporations as listed above.

**Replacement pH & ORP Sensors
For Transmitters DO NOT SUPPORT
Integrated Preamplifiers**

The instruments listed below do not support preamplifiers. Sensors to mate with these OEM pH & ORP transmitters are supplied with the appropriate internal temperature compensation and/or solution ground signals to ensure compatibility. A sensor hook-up schematics for interfacing to the given OEM pH/ORP transmitter is supplied with each sensor, and some of the most common wiring schematic are posted on our website (please inquire for any not listed). If longer cable runs may be required for your planned installation, it is recommended to select a transmitter that supports preamplifiers (see list to the left).

Fully Supported Hardware - FULL COMPATIBILITY

Manufacturer	pH & ORP Transmitters
Endress+Hauser (a.k.a. E+H)	LEGACY: CPM152, CPM280, CPM431 MODERN: CPM153, CPM223, CPM253
Mettler-Toledo International (formerly Ingold)	LEGACY: 1120, 1140, 2050, 2100, 2220, 2400, 2500, 2800X, 2050e, pH 2100-PA, pH 2100e MODERN: M200, M300, M400, M700, M800
ABB (formerly TBI-Bailey)	LEGACY: TB515, TBN580, TB701/702, 4630, 4631, 4635, 4636, AX416, AX436, AX468, AX460, AX466 MODERN: AX460, AX416, AX436, APA592, TB82pH, TB84pH
Knick	LEGACY: Stratos Eco 2402 MODERN: Stratos Evo, Stratos Pro A2 pH, Stratos Pro A4 pH, Stratos Eco 2405 pH, Stratos 2221 pH, Stratos Stratos 2231 pH, Protos 3400(X)-035, PHU 3400(X)-110

* ASTI offers pH & ORP sensors compatible with the transmitters listed above as an alternative to mating OEM pH & ORP sensors detailed.

Trademarks (indicated with ™) are registered to the respective corporations as listed above.



**Replacement pH & ORP Sensors
For Transmitters that support and/or require
Integrated Preamplifiers**

The instruments listed below require and/or support integral preamplifiers. Sensors to mate with these OEM pH & ORP transmitters are supplied with the appropriate integrated temperature compensation element, solution ground & OEM compatible high-impedance CMOS operational amplifier (a.k.a. preamplifier) as may be required to ensure full compatibility and optimal performance. Some manufacturers and analyzer models can support both sensors with or without preamplifiers on the same instrument. A sensor hook-up schematics for interfacing to the given OEM pH/ORP transmitter is supplied with each sensor, and some of the most common wiring schematic are posted on our website (please inquire for any not listed).

Supported Hardware with Some Known Issues

LIMITED COMPATIBILITY

Manufacturer	pH & ORP Transmitters
Rosemount Analytical Liquid Division, Part of Emerson Process Management	LEGACY: 1054, 1054A, 1054B, 1055
HACH (formerly Great Lakes Instruments, a.k.a. GLI)	LEGACY: 33, 53, 60, 62, 63, 70, 83, 90, 95, 570, 670, 671, 690, 691, 692, P33, P53, P63 MODERN: si792, si794, PRO-P3 GLI PRO series, sc200
GF (Georg Fischer) Signet a.k.a +GF+	LEGACY: 710, 2720, 9030, 9040, 8710, 5700 MODERN: 9900, 8900, 8750

* ASTI offers pH & ORP sensors compatible with the transmitters listed above as an alternative to mating OEM pH & ORP sensors detailed.

Trademarks (indicated with TM) are registered to the respective corporations as listed above.

**Replacement pH & ORP Sensors
For Transmitters DO NOT SUPPORT
Integrated Preamplifiers**

The instruments listed below do not support preamplifiers. Sensors to mate with these OEM pH & ORP transmitters are supplied with the appropriate internal temperature compensation and/or solution ground signals to ensure compatibility. A sensor hook-up schematics for interfacing to the given OEM pH/ORP transmitter is supplied with each sensor, and some of the most common wiring schematic are posted on our website (please inquire for any not listed). If longer cable runs may be required for your planned installation, it is recommended to select a transmitter that supports preamplifiers (see list to the left).

Supported Hardware with Some Known Issues

LIMITED COMPATIBILITY

Manufacturer	pH & ORP Transmitters
Yokogawa Electric Corporation (Formerly Johnson Yokogawa Controls, a.k.a. JYC)	LEGACY: pH/ORP 200, pH/ORP 400, pH/ORP 202, pH/ORP 402, pH150, pH100, OR100 MODERN: PH450G, PH202G

* ASTI offers pH & ORP sensors compatible with the transmitters listed above as an alternative to mating OEM pH & ORP sensors detailed.

Trademarks (indicated with TM) are registered to the respective corporations as listed above.

Most of the pH/ORP transmitter models listed also have a both contacting conductivity and toroidal (inductive contactless) conductivity transmitter counterpart to which ASTI can also supply alternative sensors to the OEM model sensors. Please inquire for any such conductivity retrofit and replacement sensor needs as well as for the pH & ORP measurements.

The manufacturers and models detailed on this webpage are not a complete listing of the supported OEM pH & ORP transmitters, analyzers and controllers to which ASTI can retrofit our replacement pH, ORP and conductivity sensors.

PLEASE INQUIRE FOR COMPATIBILITY INFORMATION ABOUT ANY INSTRUMENTATION NOT LISTED HERE

Naturally, all the ASTI pH, ORP and Ion selective (ISE) sensors are compatible with our own **2TX, 3TX and 4TX transmitters**

Last Revised 2017-05-15