



Configurations (ISE)

DIMENSIONAL DRAWINGS FOR THE FOLLOWING:

3/4"-1" MNPT Inline, Immersion & Submersion Ion Selective Model 6XX0 Series ISE Sensors

1"-1.25" MNPT Immersion & Submersion Model AB 6100 Special Fluoride Ion Selective (ISE) Sensor

1" MNPT Twist Lock Quick Disconnect Bayonet Style Ion Selective Model 8XX0 Series ISE Sensors

Sanitary & HOT-TAP Valve Retractable Style Ion Selective Model 5XX0 Series ISE Sensors

3/4"-1" MNPT INLINE, IMMERSION & SUBMERSIBLE SERIES SENSORS DIMENSIONAL DRAWINGS

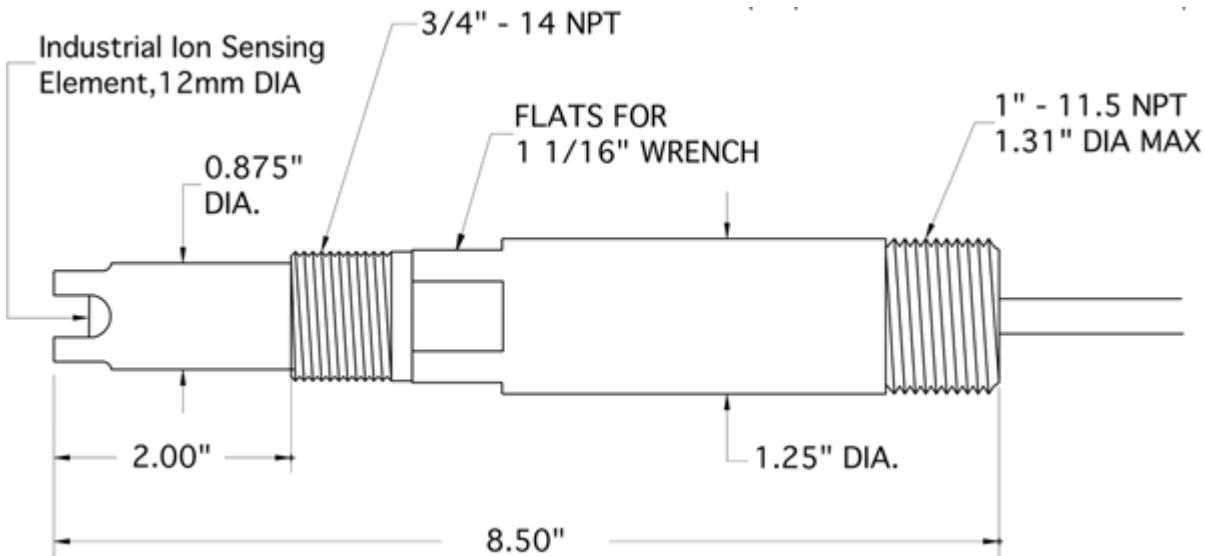

1"-1.25" MNPT IMMERSION & SUBMERSIBLE SERIES SENSORS DIMENSIONAL DRAWINGS

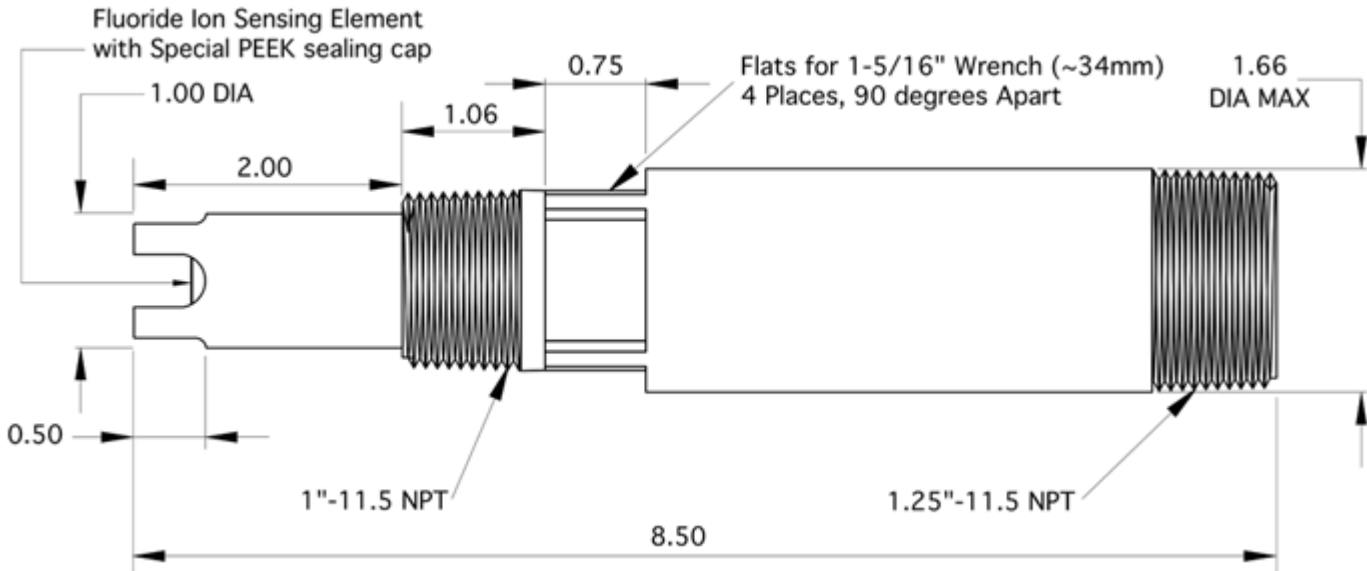

**3/4"-1" MNPT Ion Selective (ISE) Sensor 6XX0 Series
Dimensional Drawing 6-ISE**

AB 6100H Fluoride (F^-)
 AB 6110 Chloride (Cl^-)
 AB 6130 Bromide (Br^-)
 AB 6140 Iodide (I^-)
 AB 6160 Cyanide (CN^-)
 AB 6170 Silver (Ag^+) AB 6410 Ammonium (NH_4^+)
 AB 6430 Sodium (Na^+)
 AB 6440 Calcium (Ca^{2+})
 AB 6480 Perchlorate (ClO_4^-)
 AB 6490 Lithium (Li^+)
 AB 6610 Chloride (Cl^-)
 AB 6810 Nitrate (NO_3^-)
 AB 6820 Nitrite (NO_2^-)

**1.00"-1.25" MNPT AB 6100 Special Fluoride Ion Selective (ISE) Sensor Dimensional
Drawing F-1-ISE**

AB 6100 Special Fluoride (F^-) Ion Selective Sensor is the ONLY MODEL SUITABLE FOR Use in Acid Etching Process Media Service Conditions at Elevated Temperatures or Applications requiring strong acid cleaning to remove fouling from sensor *Inquire to ASTI factory for any fluoride ion measurement to determine if the special AB 6100 is require for your desired field measurement.*

**1" MNPT TWIST LOCK QUICK DISCONNECT BAYONET STYLE
INLINE SERIES SENSORS DIMENSIONAL DRAWINGS**

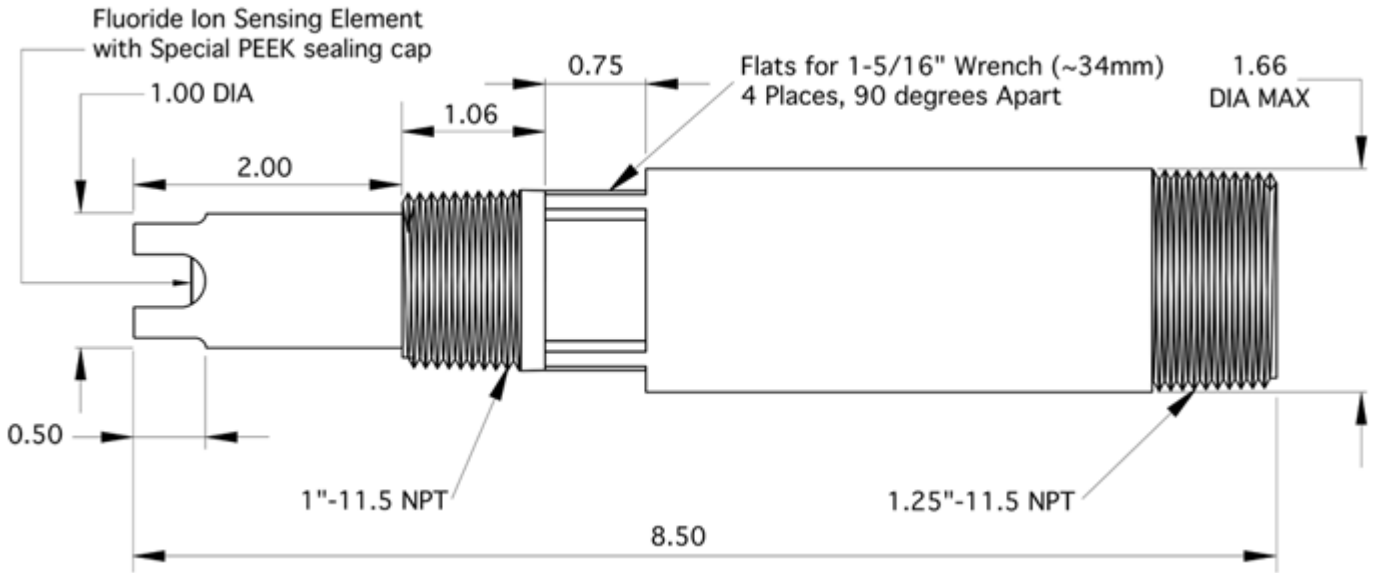

**3/4" MNPT SANITARY & HOT-TAP STYLE
SERIES SENSORS DIMENSIONAL DRAWINGS**

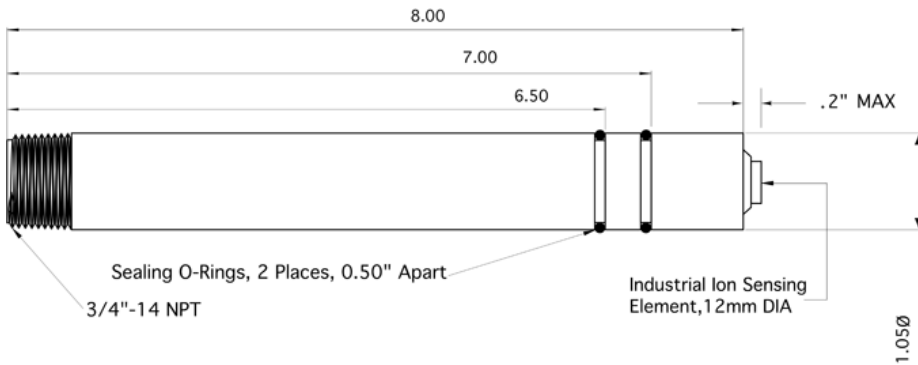

**1" MNPT Twist Lock Ion Selective (ISE) Sensor 8XX0 Series
Dimensional Drawing 8-ISE**

- AB 8100 Fluoride (F^-)
- AB 8110 Chloride (Cl^-)
- AB 8130 Bromide (Br^-)
- AB 8140 Iodide (I^-)
- AB 8160 Cyanide (CN^-)
- AB 8170 Silver (Ag^+) AB 8410 Ammonium (NH_4^+)
- AB 8430 Sodium (Na^+)
- AB 8440 Calcium (Ca^{2+})
- AB 8480 Perchlorate (ClO_4^-)
- AB 8490 Lithium (Li^+)
- AB 8610 Chloride (Cl^-)
- AB 8810 Nitrate (NO_3^-)
- AB 8820 Nitrite (NO_2^-)

3/4" MNPT Sanitary & HOT-TAP Ion Selective (ISE) Sensor 5XX0 Series Dimensional Drawing 5-ISE

- AB 5100 Fluoride (F⁻)
- AB 5110 Chloride (Cl⁻)
- AB 5130 Bromide (Br⁻)
- AB 5140 Iodide (I⁻)
- AB 5160 Cyanide (CN⁻)
- AB 5170 Silver (Ag⁺) AB 5410 Ammonium (NH₄⁺)
- AB 5430 Sodium (Na⁺)
- AB 5440 Calcium (Ca²⁺)
- AB 5480 Perchlorate (ClO₄⁻)
- AB 5490 Lithium (Li⁺)
- AB 5610 Chloride (Cl⁻)
- AB 5810 Nitrate (NO₃⁻)
- AB 5820 Nitrite (NO₂⁻)

Installation Details for 1" MNPT KYNAR® PVDF and KETASPIRE® PEEK Twist Lock Receptacles for Quick Disconnect Bayonet Inline Use

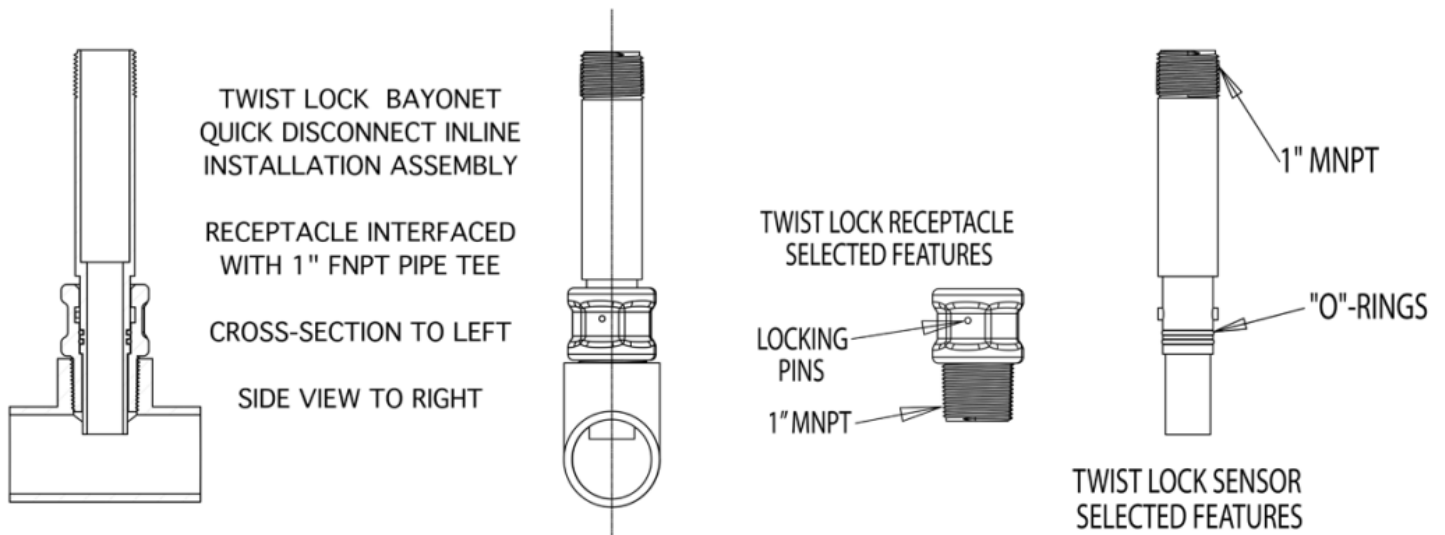



The dimensional detail drawing for the KYNAR® PVDF and KETASPIRE® PEEK Twist Lock Receptacles is linked below: [1"MNPT Twist Lock Receptacle in KYNAR® PVDF or KETASPIRE® PEEK Material of Construction](#) Please carefully check the recommend maximum temperature and pressure rating of your twist lock sensor prior to installation. Note that the max temperature pressure will be limited by the ion selective sensor selected rather than the capabilities of the 1"MNPT KYNAR® PVDF and KETASPIRE® PEEK Twist Lock Receptacle twist lock quick disconnect bayonet receptacle process fitting.

Chemical Resistance Charts for Materials of Construction of Ion Selective Sensor Bodies & 1"MNPT Twist Lock Receptacles for Bayonet Style Quick Disconnect Inline Installations

<p>6XX0, 8XX0 & 5XX0 Series Ion Selective (ISE) Sensors Body Housing RADEL® Poly-Phenyl-Sulfone, PPSU</p>	<p>KETASPIRE® 1"MNPT Twist Lock Receptacles Poly-Ether-Ether-Ketone, PEEK</p>	<p>KYNAR® for 1" MNPT Twist Lock Receptacles & Selected Special Order Junction Configurations (Poly-Vinylidene-Fluoride, PVDF) HDPE (High-Density Polyethylene) is employed for most support matrix for solid-state conductive polymer reference systems in ISE sensors</p>
<p>RADEL® R-5000 NT Chemical Resistance Chart RADEL® R-5000 NT Thermal & Mechanical Performance Data</p>	<p>KETASPIRE (PEEK) Chemical Resistance KETASPIRE® KT-880 NT Specifications</p>	<p>KYNAR (PVDF) HDPE</p>

® RADEL and KETASPIRE are registered trademarks of SOLVAY

® KYNAR is a registered trademarks of ARKEMA